

ELSAFE INDIA

Leading The Way To Safety
Cochin - Chennai - Bangaluru - Hyderabad - UAE

www.elsafeindia.com, info@elsafeindia.com
CALL US AT 0484-2575199, 08848281812

CALL US AT
08848281812



QUOTATION

Project Name: LSG ULTIMATE PKG
Quote #: 24OQLSGP2
Company: Residential-Protection Packages



These are Residential Packages for Houses at Kerala State only, ALL KERALA FREE DELIVERY, NO HIDDEN CHARGES, FIXED RATE

Terms: ***
Ship via: Land Cargo
C&F Landed at site
Weight: *** As applicable

LSG Protect-TGD30

Supply of External Lightning Protection System LSG PROTECT – Thunderguard® ESEs are made of non-corrosive materials, utilize advance and sustainable technologies, maintain a 15 Yrs warranty, are independently tested certified to NFC 17102 and UNE 21186 standards. Level IV 75 mtrs by capturing dangerous lightning discharges and safely channelling it to earth. All mouting mast connected with FRP mast for Protection of Side Flash Lightning Current and Test link Joint Kit IP 55/65 weather proof enclosure for testing the earth pit. Insulation material used to electrically isolate the panels, The lightning air terminal is maintenance free type & frequent testing is not necessary for ensuring the working of it. The central finial shall be elevated above the spheroid and it is sharp pointed & made-up of stainless steel alloy for long and reliable operations. An air gap provided between the individual electrically isolated 4 panels and the finial tip of the central rod.

Number	Item	Description	Qty.	Unit	Unit Cost	Total Cost
		Lightning Protection System			(in INR)	(in INR)
1	ThunderGuard 30	LSG ThunderGuard 30 Lightning Arrester with SS ADAPTOR	1	No	INR 51,400	INR 51,400
2	Earthing	Maintenance free Earthing For Lightning Arrester: Using 2 no's of 2 Mtr long / 250 micron, 14.2mm Dia DOLPHIN UL Listed Copper bonded Steel Rod & TEKSO ELECTRON FILL , a low resistivity ,RoHS certified & Maintenance free Grounding Enhancement backfill Compound Model:-TEKSO ELECTRON FILL(22 kg)	1	Set	INR 12,000	INR 12,000
3	Elevation Mast	Specially designed 3 mtrs GI mast Setting , and 1 mtr FRP top section insulation mast; Roof top/Tower side mounting arrangement & fixing accessories (anchoring rope & anchoring plate, Base -for roof top installation). The mast coated with paint for additional protection,Cable connector Adaptor	1	Set	INR 8,000	INR 8,000
4	Down Conductor	50 Sq MM V Guard HRFR Insulated Copper Cable	25	Mtrs	INR 700	INR 17,500
5	Surge Protector Device	LSG Protect BC100 Imported 3 Phase 1+2 Combicontrol 100KA AC Surge protection device	1	No	COMPLEMENTARY	COMPLEMENTARY
6	Lightning Strike counter	LSG PROTECT Imported 6 Digit analogue lightning strike counter	1	No	INR 10,000.00	INR 10,000.00
7	Equipotential bonding Device	LSG PROTECT EQB50 , Lightning impulse current Limp 50KA 10/350, Imax 8/20 50KA, Protection against reverse path effect and equal distribution of lightning current to earth rods.	1	No	INR 14,000.00	INR 14,000.00
8	Installation	Installation of ESE Lightning Protection System, tester system, SPDs with Down conductor routing from the LA terminal to the earth pit. Earth termination, fixing & Backfilling	1	Job	INR 11,000	INR 11,000
Quotation Valid For 20 days				GRAND TOTAL		INR 1,23,900.00

Terms & Conditions

- 1 Price Landed at site
- 2 Customers Scope: Material safety will be customer scope after delivery
- 3 Approvals /Permission of work/storage of tools & equipment/safety etc : At customers scope

Thank you,

Best Regards

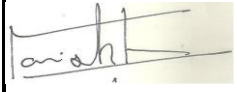

ELSAFE PROTECTION & CONTROL SYSTEMS

CALL US AT 08848281812



Doc. No. : ES252612121

Rev. No. :

Rev. Date :



CATALOGUE

**LIGHTNING -SURGE PROTECTION
EARTHING & BONDING**

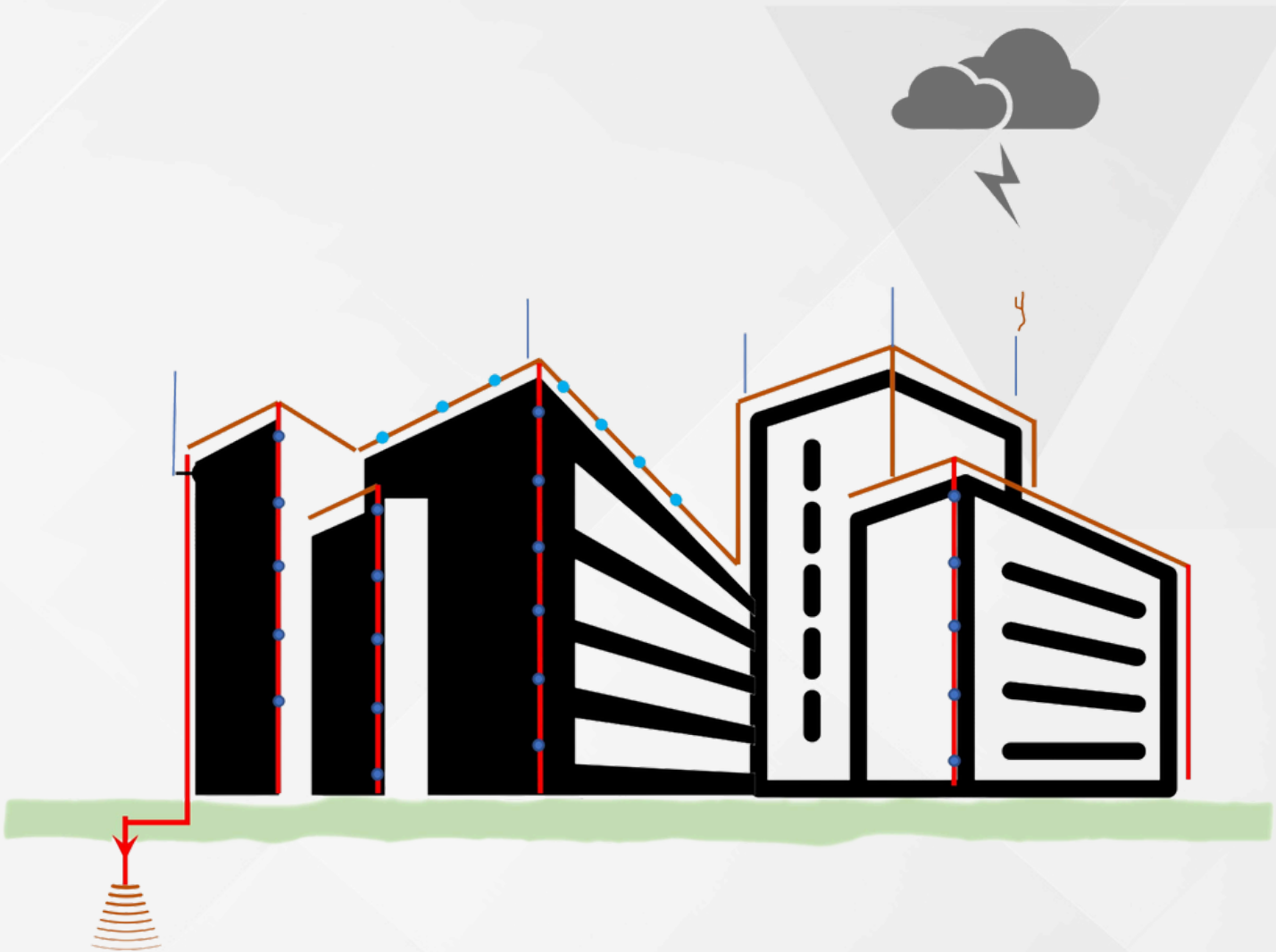

About us

We **ELSAFE PROTECTION AND CONTROL SYSTEMS** is a renowned company specialized towards enduring electrical safety cultures across a wide range of markets. We specialize in a total electrical safety model which includes Quality lightning protection system, surge protection system, low resistivity Chemical earthing.



Our brands



ALLTEC USA

ALLTEC USA is an international, full-service company specializing in customized design & engineering solutions for grounding/earthing & bonding, surge/transient protection, and lightning protection.

LSG FRANCE

LSG is a specialist company, in the fields of lightning protection, electrical earthing and surge protection. which grow the business through dynamic technical orientation and exceptional customer service

TEKSAI INDIA

TEKSAI is an ISO 9001-2023 certified company and a leading brand in India Since 2003 & Tekesai has proven itself leader in the Design, Manufacturing of Grounding System, Lightning Protection System & Electrical installation

Our Certifications



RDSO
Research Design & Standards Organisation



Our Products

01

ESE LIGHTNING ARRESTERS

02

CONVENTIONAL LIGHTNING ARRESTERS

03

SURGE ARRESTERS

04

**EARTHING RODS , ELECTRODES AND
EARTH COMPOUNDS**

05

**COPPER/GI/ALUMINIUM STRIPS,
CONDUCTORS, CABLES**

06

EXOTHERMIC WELDING

Our services

01

PRODUCT SALES

Our Stock management and Our Supply chain management is well appointed and best managed to Provide best customer experience and timely completion of Orders.

02

SITE VISIT & DESIGN

Understanding of the Site design, layout and their plan for electrical safety implementation all enable us to contribute efficiently; ensuring total Protection and Solution level is achieved

03

INSTALLATION

Our installation crews and field technicians perform all forms of exterior earth grounding and internal equipment bonding and grounding, including comprehensive turnkey installation service. Employees participate in continuing education and advancement courses and are ALLTEC Certified Master Installers.

04

TESTING AND SUPPORT

Our field technicians and engineers perform 3-point fall of potential tests, 4-point soil resistivity tests, and clamp-on resistance tests of grounding systems, as well as complete facility site survey and consulting services. Our staff is equipped with the latest testing equipment. Extensive experience in ground testing and design



भारतीय प्रौद्योगिकी संस्थान हैदराबाद
Indian Institute of Technology Hyderabad





ALLTEC



CONVENTIONAL LIGHTNING PROTECTION

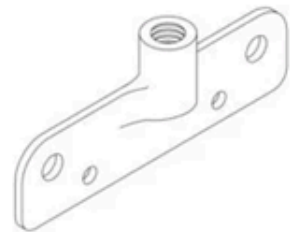
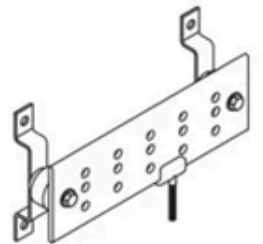
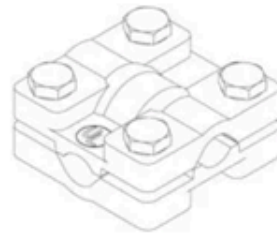
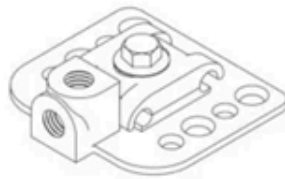



ALLTEC



ESE LIGHTNING PROTECTION





LSG PROTECT[®]



SURGE PROTECTION DEVICES





LSG PROTECT®



ESE LIGHTNING PROTECTION





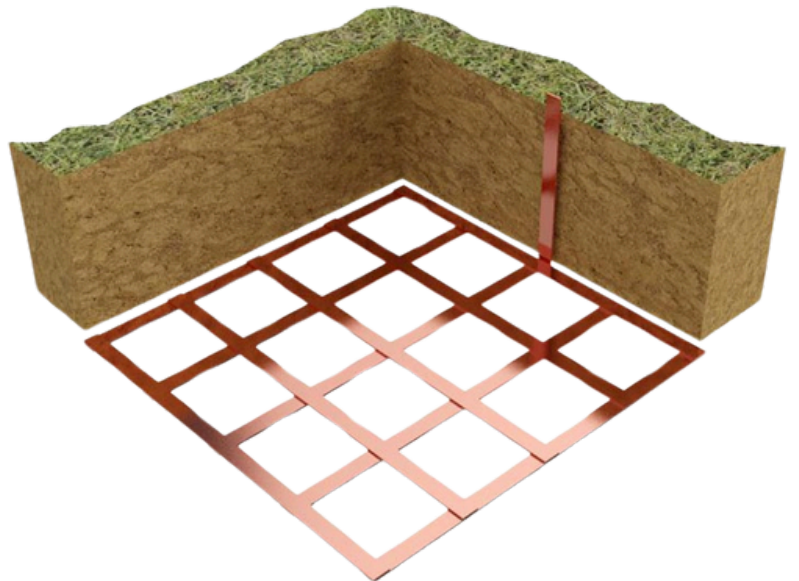
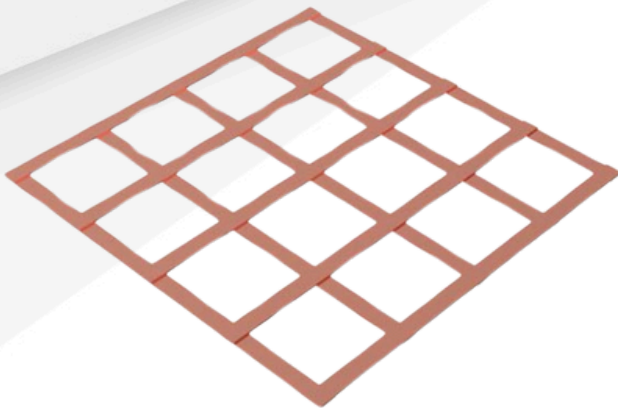
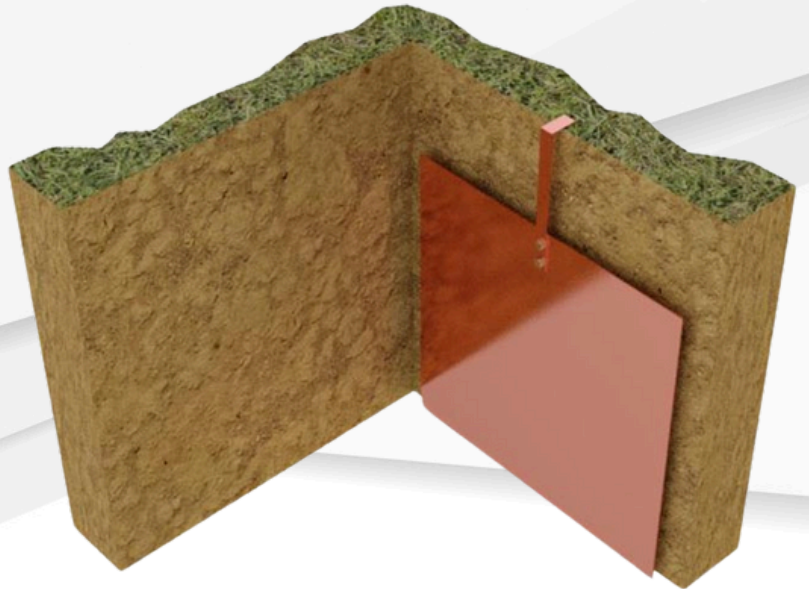
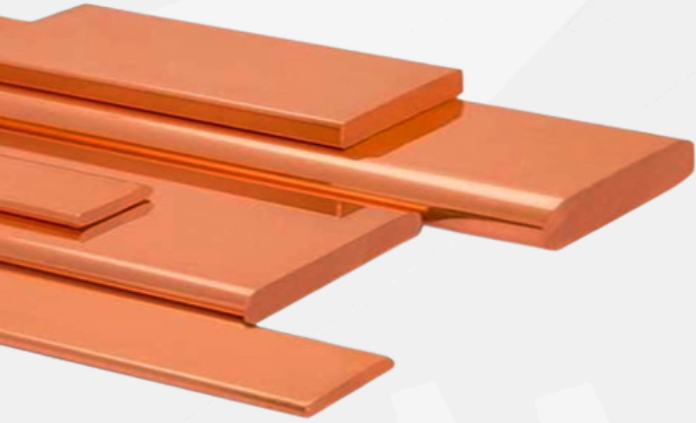



EARTHING SOLUTIONS



COPPER/GI/ALUMINIUM CONDUCTORS





CONTACT



www.elsafeindia.com

info@elsafeindia.com

+91-484-2575199, 8848281812

Elsafe Garden, West Morakkala, Kumarapuram
PO, Kakkanad, Ernakulam-683565
Kerala State, India



THUNDER **GUARD**[®]

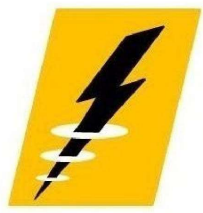

LSG PROTECT[®]

**TAKE
THE
EXTRA
STEP
TO
SAFETY**



ESE LIGHTNING ARRESTERS

THUNDER GUARD

ThunderGuard series ESE Lightning Arresters Developed and designed in our highly advanced labs is specially designed with unique design philosophy as per NFC-French Standard.

Thunderguard adopts synthesis techniques of leader discharge, impedance to limit current, air-gap discharge etc to produce leader channel in advance, improve lightning effect, reduce discharge voltage and change the discharge process of lightning current.

Thus it broaden the lightning wave, flatten the leading wave, decrease the amplitude and enlarge the scope of protection avoiding side striking and shielding failure then finally actively suppress the damage of Ground Potential Counter attack. Therefore it is an ideal device to prevent direct lightning.

ThunderGuard Series ESE lightning Arresters come in with widest Protection coverage area. Find Our protection radius coverage table for reference.



LSG THUNDERGUARD PROTECTION RADIUS			
	H(m)	ThunderGuard 30	ThunderGuard 60
LEVEL 1	2	20	32
	3	30	48
	4	40	65
	5	50	79
	6	50	79
	8	51	79
LEVEL 2	10	51	81
	2	23	38
	3	35	55
	4	47	74
	5	58	89
	6	58	90
LEVEL 3	8	59	92
	10	60	92
	2	27	42
	3	40	62
	4	53	82
	5	66	99
LEVEL 4	6	66	99
	8	68	101
	10	69	101
	2	30	45
	3	45	65
	4	59	87
LEVEL 4	5	74	108
	6	74	108
	8	76	110
	10	77	111



ESE LIGHTNING ARRESTERS **THUNDER GUARD**

Product Structure:

- Central bar
- Reflector
- Trigger gear
- Exciter
- Dead plate of exciter
- Trigger gear, reflector and central bar all are insulating
- Reflector and central bar show good electrical connection to the earth
- The base of exciter is made up of synthetic resin thus applicable to any corrosion environment



Advantages:

- Non-electronic type, long life.
- Guaranteed electrical continuity and sustainability after repeated lightning strike.
- High radius of protection for user selection.
- Non-electrical system, will not be effected by surge impact.
- Only self-activated during lightning strike and initiative intervene the lightning protection system.

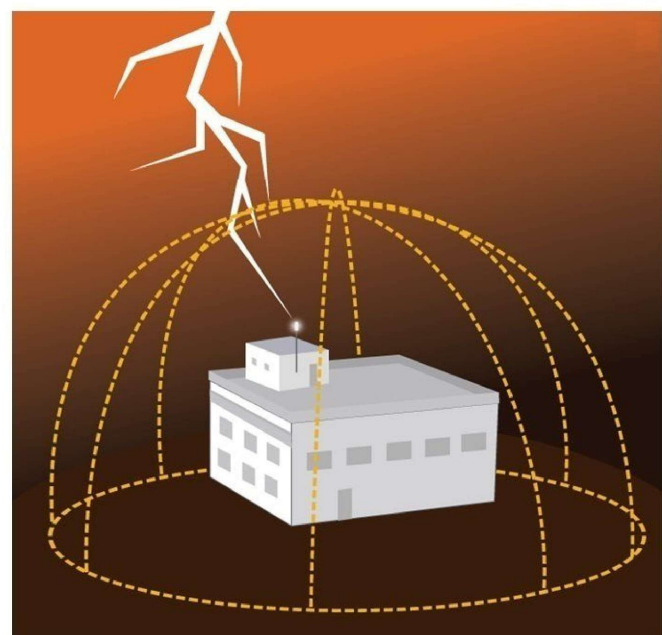

ESE LIGHTNING ARRESTERS **THUNDER GUARD**

Thunderguard 30

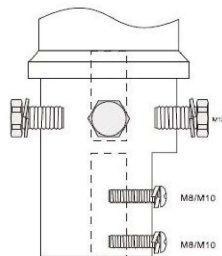
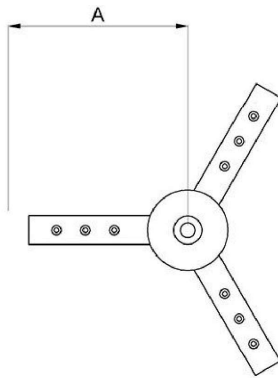
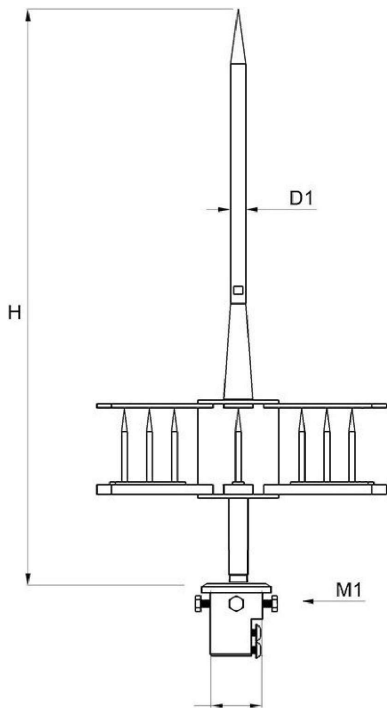

LSG TGD30[®] protection (UNE 21.186:2011, NFC 17.102:2011 and NP 4426:2013)

Content No	Material	Height (mm)	Dimension (mm)	Weight (mm)
232111	Stainless Steel	650	18	3700

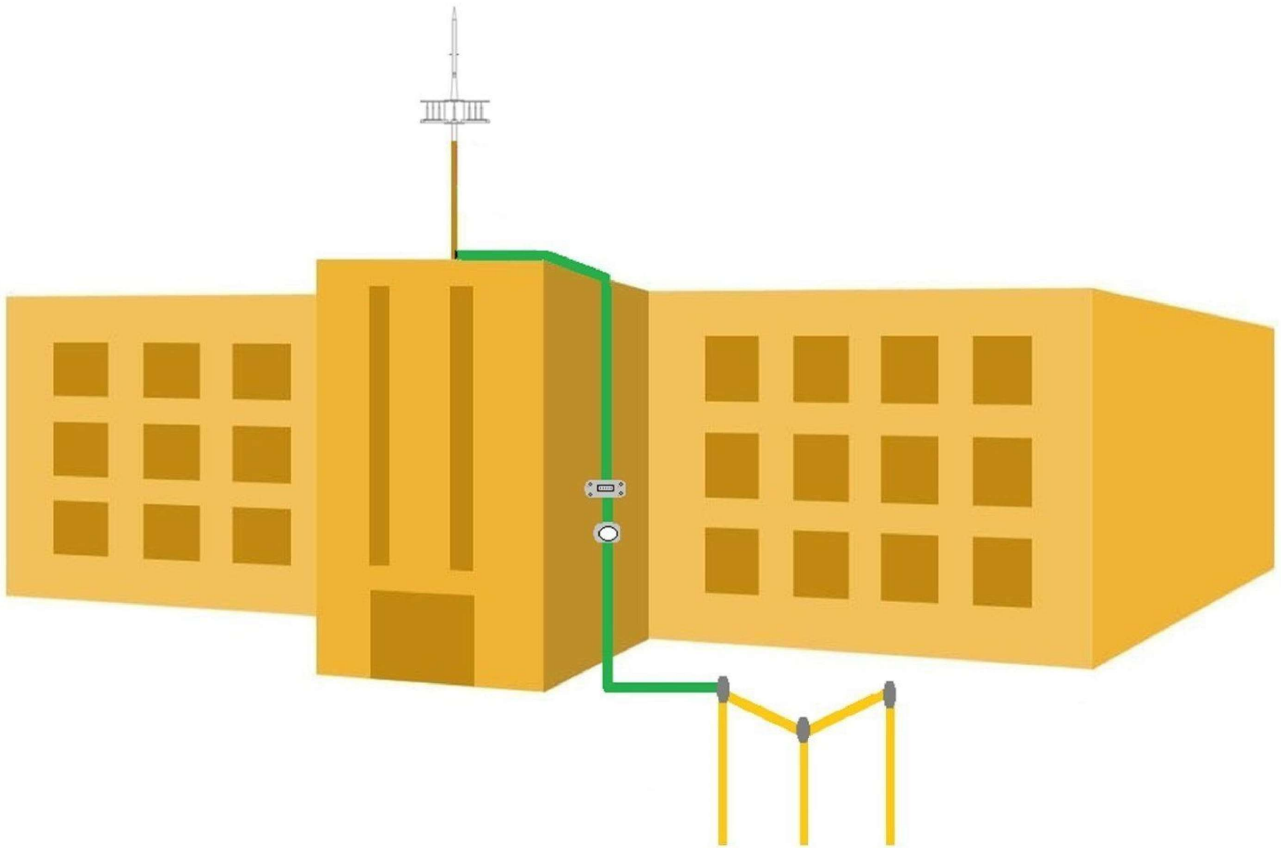

LSG PROTECT

No.1 avenue de Luxembourg, Europa tower, 94320 Thiais, France
www.lsgprotect.com, cs@lsgprotect.com
Contact No 0033-7-61-52-75-00