

# ELSAFE INDIA

Leading The Way To Safety  
Cochin - Chennai - Bangaluru - Hyderabad - UAE

www.elsafeindia.com, info@elsafeindia.com  
CONTACT US AT: 0731-4600-313

CALL US AT

0731-4600-313



## QUOTATION

Project Name: TEK1000-PREMIUM PACKAGE  
Quote #: 24OQTEK10001  
Company: Residential-Total Protection



These are Residential Packages for Houses at Kerala State only, ALL KERALA FREE DELIVERY, NO HIDDEN CHARGES, FIXED RATE

Revision:  
Terms: \*\*\*  
Ship via: Land Cargo  
C&F Landed at Site  
Weight: \*\*\* As applicable

Number	Item	Description	Qty.	Unit	Unit Cost	Total Cost
		<b>Lightning Protection System</b>			(in INR)	(in INR)
1	LA TERMINAL	TeksoPrevent MODEL : TEK1000 ( Lightning Arrestor) Supply of Lightning arrestor Tekso Prevent Air terminal which is a Copper built lightning arrestor. Large protection region; High performance 2. High quaity 3. Strong anti-corrosion and conductivity	1	No	INR 23,700.00	INR 23,700.00
2	Earthing	Model : TEKSAI Copper rod 2 Nos Spec : 2 Mtr Length x 14.2 mm dia x250 micron (ISO 9001-2008 Certified Company), CPRI Approved, Maintance free Earthing. Model : TEKSAI ELECTRON - High Conductive Concrete ( High Conductive & Anti Corrosive Compound ) Application : Superior Choice & Reliable Performance for all Soil / Sandy / Rocky / Filled sand location ELECTRON -- 22 kg Bag	1	set	INR 8,000.00	INR 8,000.00
3	Down conductor	Vguard Lightning Arrester GRADE ISI MARKED 50 Sqmm COPPER CABLE	25	Mtrs	INR 700.00	INR 17,500.00
4	Elevation Mast	Specially designed 3mtr GI mast, 1 Feet FRP Mast with LA Base, adaptor, Ancoring rope if required and Accessories	1	set	INR 3,700.00	INR 3,700.00
5	Installation	Installation	1	Nos	INR 7,000.00	INR 7,000.00
6	Surge Protector Device	LSG Protect Imported 3 Phase 50KA 1+2 Combicontrol AC Surge protection device	1	No	Complementary	Complementary
Quotation Valid For 20 days			GRAND TOTAL		INR	59,900.00

**Terms & Conditions**

- 1 Price Landed at site
- 2 Customers Scope: Material safety will be customer scope after delivery
- 3 Approvals /Permission of work/storage of tools & equipment/safety etc : At customers scope

*Thank you,*

**Best Regards**

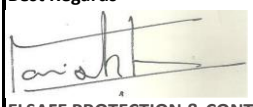

**ELSAFE PROTECTION & CONTROL SYSTEMS**

**CONTACT US 0731-4600-313**



Doc. No. : ES242512121

Rev. No. :

Rev. Date :

*Sales and Service Provider of ALLTEC USA / LSG FRANCE/ TEKSAI-INDIA, Lightning Arresters, Surge Arresters, Maintenance free Earthing*

## Certificate of Quality

### Test Details

Serial Number	: <b>16021025</b>	Volume resistivity, IEC60093	: 1E13/1E9 Ω*m
Product Name	: TEKSOPREVENT	Surface resistivity, IEC60093	: * / 1E10 Ω
		CTI, solution A, IEC60112	: 600
Model Number	: TEK1000	<b><u>Mechanical properties</u></b>	
		Tensile modulus, ISO527-2	: 3500/1500 MPa
		Yield stress, ISO527-2,	: 75/45 MPa
Date	: 03-28-2016	Yield strain, ISO527-2,	: 4/20 %
		Strain at break, ISO527-2	: 6/250 %
		Charpy V-notch impact strength,-ISO179/1eU:	80/N kJ/m2

### **Technical specification**

Melting temperature,	: 1001 °C
ISO3146 Density, ISO1183	: 1.16 g/cm3
Melt volume rate MVR 275/5,	: 140 cm3/10 min.
ISO1133 Molding shrinkage, Test	: 0.8%
box 1.5mm Moisture absorption,	
equilibrium-23°C/50% r.h. ISO62	: 2.6 – 3.2%

### **Thermal properties**

Deflection temperature 1.8MPa, ISO75-2	: 800 °C
Deflection temperature 0.45 MPa, ISO75-2	: 1600 °C
RTI electrical ( thickness 1.5mm ), UL746B	: 1050 °C

### **Flammability**

UL94 rating	: V-0 ( >=0.4 )
Hot wire ignition, ASTM D 3874-	: 2 ( >=1.5 )
88 High current arc ignition,	: 0 ( >=0.4 )
UL746A,Fire/ignition performance-	
( UL94+HAI+HWI ), UL746C	: 1.5 mm
GWFI, IEC60695-2-12	: 1400 °F
GWIT, IEC60695-2-13	: 1350 °F
Limiting Oxygen index LOI ISO4589-2	: > 35 %
Spec. optical density of smoke Ds,-	
25kW/m2, EN ISO5659-2	: 60
Conventional index of toxicity	
CIT, - 25kW/m2, EN ISO5659-2	: 1

### **Electrical properties**

Dielectric constant at 1MHz, IEC60250	: 3.6/6
Dissipation factor at 1MHz, IEC60250	: 200/3000

### **Technical specification of Ball Enclosure**

Durometer Range A	: 25 -85
Tensile, Max. psi ( Mpa )	: 1300 lbf ( 10.5kN)
Elongation, max %	: 800
Specific Gravity	: 1.1
Continuous Temp Max	: 800 °C
Compression set	: Excellent

### **Environmental and Immersion Properties**

Electrical Resistivity	: Excellent*
Flame Resistance	: Good*
Impact resistance	: Good*
Tear Resistance	: Fair
Continuous Temp Max	: 1472 °F
Intermittent Temp Max	: 1122 °F
Weather change tolerance	: Excellent*
Oxidation Resistance	: Excellent*
Ozone Resistance	: C
300°F Steam Resist.	: Good*
Temperature and Environment stress -	
Screening tests	: Good*
Salt water dipping test	: Good*
UV test	: Good*
Vibration Endurance test	: Excellent*
Impulse Current Test (40KA-240KA)	: Good*

**(Equipment are tested only on one piece in a lot of 100 pieces\*)**



Stamp & Signature  
 Kent  
 Head, Quality Control

**Quality Check Result: PASSED**

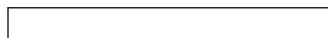



AC SPD MODULE MODEL: **LSGBC50(2022)**

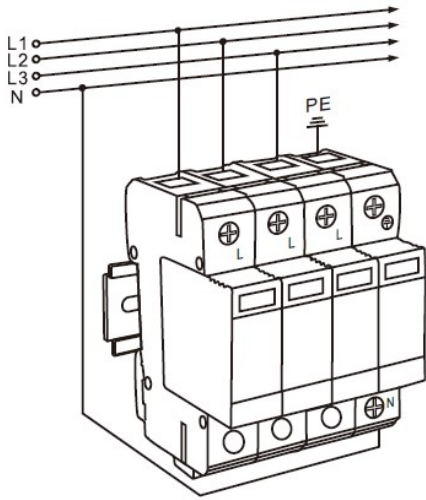

APPLICATIONS

- B+C class Surge Protective Device for AC Power System.
- Sensitive electronic equipment
- Telecom centers
- Automatic control centers
- Intelligent buildings
- Industrial enterprises
- Medical institutes

FEATURES:

- DIN rail mounting for easy installation
- Plug connectors for quick and easy connection or rewiring
- 50kA lightning impulse current Iimp
- Thermal disconnect device
- Status indicators visually verify protection level

TECHNICAL PARAMETER:

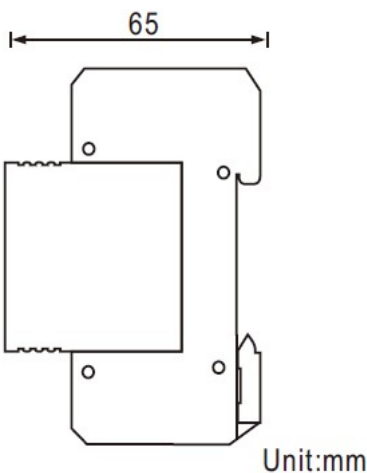
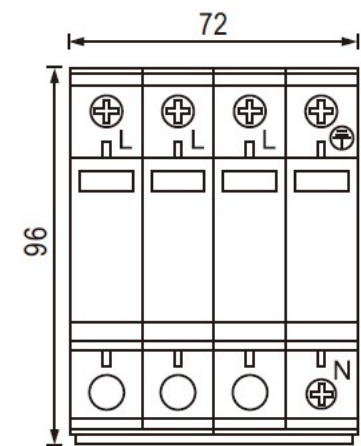

Model	LSGBC50-2022
<b>Electrical Parameter</b>	
Nominal working voltage Un	50/60Hz 220/380V,
Max. continuous operating voltage Uc	385V
Nominal discharge current (8/20μs) In	50kA
Lightning impulse current(10/350μs) Iimp	25kA
Protection level @20kA , 8/20μs Up	1500V
Response time tA	<25ns
Protection model	L1/L2/L3-N,N-PE
<b>Mechanical characteristics</b>	
Dimension	65 (H)×72 (W)×96(L)mm
Weight per unit	0.47KG
Mounting	35mm DIN rail
Connecting diameter	≥10mm <sup>2</sup>
IP code	IP20
Working conditions	Temperature: -50 to 80°C , Relative humidity: ≤95%
Approval	FCC, CE, ROHS

# LSGBCN100 Power Surge Protective Device

## Product Manual

### Introduction

1. Standard : IEC 61643-11:2011 Low Voltage Surge Protective Devices (SPD) Part 11: Performance requirements and test methods for surge protective devices for low-voltage power supply systems.
2. Features : surge protective device has over-voltage protection, over-current protection, over-heat protection, fault indication, and remote signal alarm function. The product has good sealing, dust-proof, flame-retardant functions, and can work stably for a long time in harsh environments .
3. Application Scope: AC power line protection for low-voltage power supply systems and lightning surge protection for power equipment.
4. Working Environment: Installed indoors; the temperature is  $-5^{\circ}\text{C} \sim +40^{\circ}\text{C}$ , the humidity is  $5\% \sim 95\%$ ; the air pressure is between  $80 \text{ kPa} \sim 106 \text{ kPa}$ , the corresponding altitude is  $+2000\text{m} \sim -500\text{m}$ .

### Technical Parameters

**Table 1: Specification Parameter Table of Power Surge Protective Device**

parameter Model	Maximum Continuous Operating Voltage $U_c$	Nominal Discharge Current $I_n$ (kA)	Maximum Discharge Current $I_{max}$ (kA)	Voltage Protection Level $U_p$ (kV)	Protection Mode	L1×W×H (mm) 1P
LSGBCN100	275V AC	60	100	2.5	1. L-PE N-PE 2. L-N-PE	91*27*66

Mark: 1P means 1 module, when the protection mode is 1, the product has a combination of 1P, 2P, 3P, 4P, when the protection mode is 2, the product is a 3+1 combination; when the nP module is combined, the width is 1P width×n, length And the height does not change.

### Installation Parameters

1. All levels of surge protective device for power lines should be installed at the entrance of the line into the building, the interface of the lightning protection zone and near the protected equipment.
2. The phase wire of the surge protective device should be connected by copper wire with a cross-sectional area  $\geq 6\text{mm}^2$ , and the grounding wire should be connected by a copper wire with a cross-sectional area  $\geq 10\text{mm}^2$ . The connecting wire should be as short, straight and neat as possible, and its length should not exceed 0.5m, and the grounding resistance should be less than  $10\Omega$ .
3. The bend angle of the grounding wire and the surge protective device connection wire should be greater than 90 degrees when turning, and the bend radius should be greater than 10 times the diameter of the wire. It is forbidden to make a loop when the connection wire is installed.
4. The wiring method for protection mode L-PE, N-PE (take 4P as an example) is shown in Figure 1, and the wiring method for protection mode LN-PE (take 3+1 as an example) is shown in Figure 2; the product has a remote monitoring and alarm function , the wiring method is shown in Figure 3 , and the product appearance size diagram is shown in Figure 4; the appearance of all products involved in the diagrams shall prevail in kind!

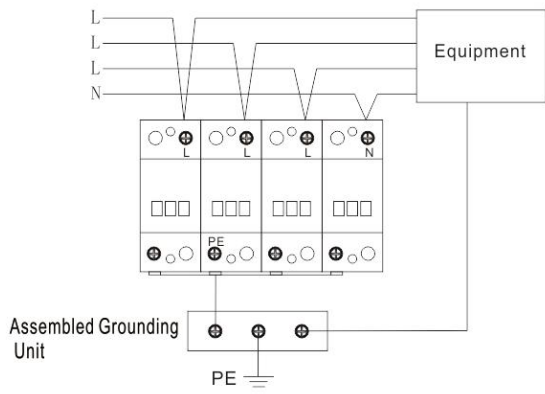

Figure 1: L-PE N-PE protection mode (4P) wiring diagram

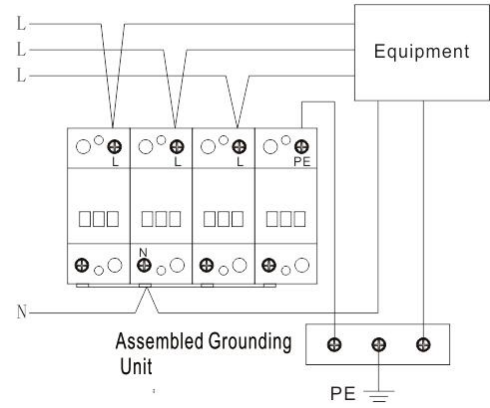
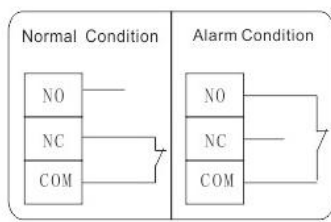
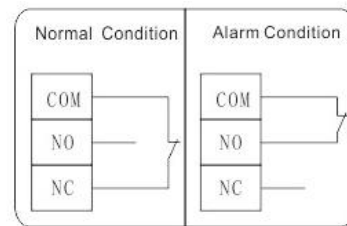

Figure 2: L-N-PE protection mode (3+1) wiring diagram



Mode 1



Mode 2

Figure 3: Schematic diagram of remote alarm status as mode 1, where DK-50G is as mode 2.

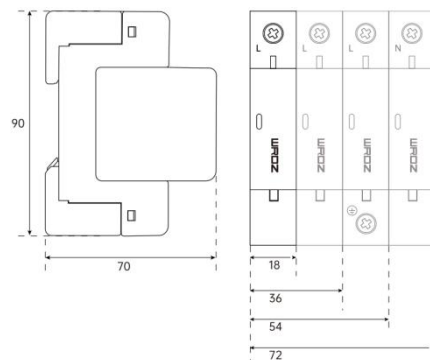

Figure 4: Schematic diagram of product size

### Maintenance

For modules with an indicator window, when the module is damaged, the indicator window turns red. For modules without an indicator window, determine whether the module is damaged according to the status indication of the remote alarm terminal. See Figure 3 for details. If the module is damaged, remove the damaged module and replace it with a new one.

## Lightning Strike Counter User Manual

### I .Introduction

Lightning strike counter is a universal counter. When the lightning protection circuit system is normal, no current flows on the discharge line, and the lightning strike counter does not count; when lightning current discharge occurs in the line, the lightning protection circuit discharges lightning current to the ground, and there is current on the discharge line. When it flows through, the counter is coupled to the induced voltage, causing the counter to count.

Lightning strike counter is suitable for all SPDs, lightning rods, etc. It can sense and discharge lightning current, and the cumulative number of lightning strikes is displayed on the counter. The product counts accurately and does not malfunction; it works without power supply, the counting value will not be lost for a long time, and cannot be reset to zero; it has dust-proof, waterproof and other functions.

### II .Technical Parameters

1. Nominal Discharge Current  $I_n$  (8/20 $\mu$ s): 4kA ~ 150kA;
2. Impulse Discharge Current  $I_{imp}$ (10/350 $\mu$ s): 4kA ~ 50kA;
3. Maximum Diameter of Down Conductor  $D \leq 20$ mm, Maximum Width of Flat Steel < 35mm, Thickness < 12mm;
4. Counting Number: 0-999999;
5. Protection Level: IP65;
6. L×W×H (mm) : 132×69×50, as below,
7. Working Temperature: -40°C ~ +85°C.

### III. Installation

1. This product can be installed on the power SPD ground wire or lightning rod down wire using the matching screw and fixed metal sheet.
2. The power supply SPD ground wire or lightning rod down wire should be close to the plastic shell to avoid affecting the accuracy of counting.
3. After a thunderstorm, pay attention to check the counter value.

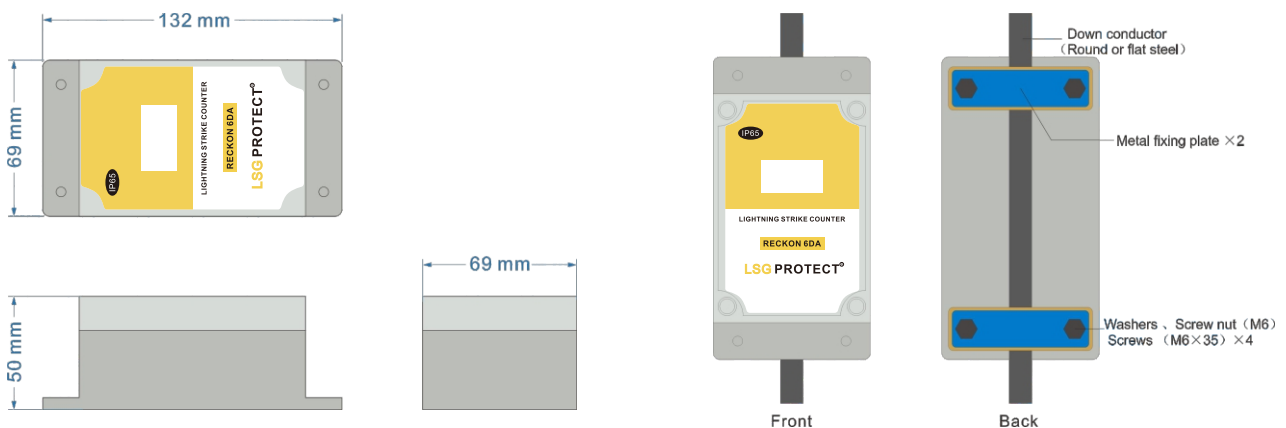

Product Installation Diagram

### IV. Maintenance

This product works without power supply, requires no special maintenance, and is durable for a long time.

**MODEL: EQB50**  
Equipotential connector manual

1) summarize

In order to prevent the difference in electric potential between various ground device, it is easy to strike back during lightning strikes, and equal potential connectors should be used.

Equipotential connectors provide equipotential connections for non-charged metal part haven't connected to earth poles. The product can be used for equipotential protection between two close independent earth poles, insulation protection of insulation flanges, and metal devices that may exceed the voltage of 1kV or more in the ground network to prevent the risk of air discharge when lightning strikes. It can also be used for the oil (gas) pipelines which with cathodic corrosion protection function, which can prevent the danger of air discharge between metal pipelines and the earth pole. The interior of the equipotential connector is composed of two electrodes with a certain distance, and if a lightning strike occurs, gas discharge will occur in the insulated cavity due to the action of over voltage, so that the original isolation between the two electrodes will be transformed into a temporary electrical connection state, thereby eliminating the potential difference.

2) technical parameter

type	EQB50	EQB100
Lightning pulse current	50ka	100ka
Lightning pulse protection voltage	1.5kv	
Response time	100ns	
size	Φ 36*90	
Connector	10mm Stainless steel screw	
Protection class	IP66	

3) installation instructions

Equipotential connectors are installed between two different ground bodies and are secured by nuts and copper connectors. Cables should be connected using multi-strand copper conductors with a cross-sectional area of  $\geq 25\text{mm}^2$ . The cables should be short, straight, and neat. Wiring diagram as P1 P2.

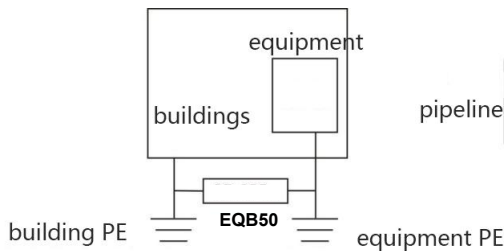

P1 Industrial/civil buildings and electrical equipment Installation wiring diagrams

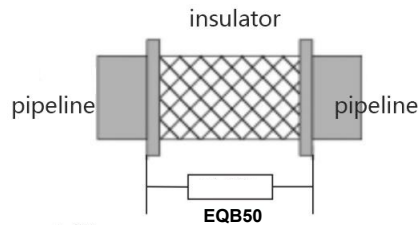

P2 Oil and natural gas pipeline installation wiring diagram

4) maintenance

The equipotential connector need tested at least once a year, or at any time as needed.





भारत सरकार Government of India  
राष्ट्रीय परीक्षण शाला (द.क्षे.)  
NATIONAL TEST HOUSE (SR)

तरमणी, चेन्नई - 600 113. Taramani, Chennai - 600 113.  
Phone : 22432374, 22431157 Fax : 22433158 email : nthsr@tn.nic.in

परीक्षण प्रमाण पत्र

347218

TEST CERTIFICATE

INTERIM/FINAL REPORT

परीक्षण प्रमाण पत्र नं Test Certificate No NTH(SR)/EL(C)/2014/00176A	जारी होने की तिथि Date of Issue 23/04/2014	कोड नं Code No 1396938243840	पृष्ठ Page 1	पृष्ठों की संख्या No of Pages 2
जिसे जारी करना है Issued To	TEKSAI POWER SECURE SOLUTION PVT.LTD.			
पता Address	3/860, BLUE STAR INDUSTRIES COMPOUND, PUDUSSERY, KANJIKODE, PALLAKKAD, KERALA-678623			
ग्राहक का सन्दर्भ सं एवं दिनांक Customer's Ref. No.	TPSS/2014	Date: 25/01/2014		
पंजिका सं एवं दिनांक Register No & Date	00176/NTH(SR)/EL(C)/08/04/2014			
परीक्षण सामग्री का विवरण Description of Test Item	Earthing material			
परीक्षण सामग्री का पहचान Identification of Test Item	Printing marking on the bag:"Teksai-Ultra"			
नमूना का विशिष्टि (यदि हों) Product Specification (if any)	Electrical Resistivity test as per customer's specification			
नमूना प्राप्ति की तिथि Date of Receipt of the Test Item	08/04/2014			
कार्य सम्पादन की तिथि Date(s) of Performance of Tests	From: 08/04/2014	To: 23/04/2014		
ब्यावहृत प्रणाली का पहचान Method(s) used for Test	Electrical Resistivity test as per customer's specification			
नमूना प्रक्रिया जहाँ प्रासंगिक हों Sampling Procedure where relevant	NA			

Tested By

N. Joseph Kalai Selvan  
Natarajan Joseph kalaiselvan

SO Electrical

Checked By

K. Jeyaraj

SO Electrical

Approved By

S.B. Nanda Kumar

Scientist-SC(Electrical)

**ARBRO™**PHARMACEUTICALS LIMITED  
(ANALYTICAL DIVISION)ISO 9001 : 2008 Certified  
**Govt. Approved Test House**

4/9, Kirti Nagar Industrial Area, New Delhi-110 015

Tele : 011-45754575 Fax : 011-45754545

e-mail : arbrolab@arbropharma.com, Website : www.arbropharmaindia.com

CERTIFICATE OF ANALYSIS

P



Sample : **EARTHING BACKFILL COMPOUND** Report No. : NR-11060906  
 Supplied By : N.S. Received On : 09/06/2011  
 Submitted By : GENIUS PROTECTION SYSTEM. (P) LTD. Mfg.Lic.No. : N.S.  
 Address : 248A, RATI COMPLEX, RAMA MKT., MUNIRKA, N DELHI. Ref. No. : N.S.  
 Batch No. Mfg. Date Expiry Date Batch Size Sample Qty  
 N.S. N.S. N.S. N.S. 100GM.

**RESULTS OF ANALYSIS**

Date of start of analysis 10-06-11 Date of Completion of analysis 13-06-11.

Description :- Black powder.

<Sl.No.>	<Parameters>	<Results>	<Limit (MAX)>
B - TOXIC METALS		:	
1.	Mercury(as Hg)	:- 0.251ppm	1000.0ppm
2.	Lead(as Pb)	:- 8.225ppm	1000.0ppm
3.	Cadmium(as Cd)	:- 0.128ppm	100.0ppm
4.	Hexa-Chromium(as Cr)	:- Less than 1.0ppm	1000.0ppm

Remark :- Observed value for Pb,Cd,Hg & Cr+6 are very low from the max limit,  
Hence sample complies the ROHS.

REMARKS : PARTY ASKED FOR THE ABOVE TESTS ONLY

Page 1 of 1

Date : Monday, June 13, 2011

  
 Person In Charge



**CENTRAL POWER RESEARCH INSTITUTE**  
(Member of STL)

Sheet 1 of 4

**CPRI**

**TEST REPORT**

<b>Test Report Number</b>	SC11376A	<b>Dated:</b> 29 <sup>th</sup> August, 2011
<b>Name &amp; Address of the Customer</b>	M/s. Teksai Power Secure Solution Pvt. Ltd., 3/860, Blue Star Industrial Compound, Pudussery, Kanjikodu, Palaghat, Kerala - 678 029.	
<b>Name &amp; Address of the Manufacturer</b>	M/s. Teksai Power Secure Solution Pvt. Ltd., 3/860, Blue Star Industrial Compound, Pudussery, Kanjikodu, Palaghat, Kerala - 678 029.	
<b>Particulars of sample tested</b>	GI Earthing Electrode	
<b>Condition of the sample on Receipt</b>	New	
<b>Type</b>	---	
<b>Designation</b>	Teksai	
<b>Serial Number(s)</b>	---	
<b>Number of samples tested</b>	One	
<b>Date (s) of test (s)</b>	10 <sup>th</sup> August, 2011	
<b>CPRI sample code no(s)</b>	SC11S1323	
<b>Particulars of tests conducted</b>	Short-Time current	
<b>Test in accordance with</b>	Customer's instruction	
<b>Standard / specification</b>	Not applicable	
<b>Sampling plan</b>	20 kA rms for 1.0 s	
<b>Customer's requirement</b>	---	
<b>Deviations if any</b>	---	
<b>Name of the witnessing persons</b>		
<b>Customer's representative</b>	Mr. Praveen.P.V	
<b>Other than customer's representative</b>	Mr. Jacob George	
<b>Test subcontracted with address of the laboratory</b>	None	
<b>Documents constituting this report (In words)</b>		
<b>Number of sheets</b>	Four	
<b>Number of oscillograms</b>	One	
<b>Number of graphs</b>	Nil	
<b>Number of photos</b>	Two	
<b>Number of test circuit diagrams</b>	One	
<b>Number of drawings</b>	One	

*N. Maheswara Rao*  
(N. Maheswara Rao)  
**Test Engineer**



*Swaraj Kumar Das*  
(Swaraj Kumar Das)  
**Joint Director**

AUTHORISED SIGNATORIES